

**Design, Manufacture and Testing of the
Hydraulic Coconut Dehusking Machine**

Mongkol Kwangwaropas¹

RP 1167

20/3/03

ABSTRACT

The hydraulic coconut dehusking machine consists of three main parts ie. the frame, the power unit including the hydraulic accessories, the lifting and dehusking mechanisms. Two sets of the hydraulic coconut dehusking machine were developed. Their hydraulic and electrical control circuits were connected in series to enable them operating contemporaneously.

Two operators are required to operate the machine. Each of them put a coconut on the lifting mechanism in order to start the working cycle automatically. As a result, the nut are immediately pushed up and seized by the holding teeth under the supplement of the hydraulic reducing circuit. After that the dehusking mechanisms started operating via the sequence circuit. At the end of the cycle, both mechanisms return to their original positions. Some remaining fibrous is taken out manually from the nut subsequently. The continuous dehusking speed was found to be 22.2 seconds per 2 coconuts.

Key Word : Dehusking machine, coconut

-
1. Associate professor in Agricultural Engineering Faculty of Engineering, Kasetsart University.

INTRODUCTION

Coconut is one of the worlds' economic crop. In Thailand, the local consumption is about 700 million coconuts each year. It is used for many purposes such as for daily cooking, food industry, making cosmetics and medicines etc. At present, most coconut is dehusked manually. It is a hard work and required very skill labour. In Thailand, shortage of skill dehusking labour are becoming more serious. Some private enterprise claimed that hundreds of thousand coconut was left spoiled because of insufficient labour to dehusked it before shipping. This problem causes losing millions of Bath each year.

The hydraulic dehusking machine was first designed and developed in 1990 (Kwangwaropas, 1991). It was improved later on in order to suit the requirement of the coconut industrial sector. It is a complicated machine but once it is setted and adjusted, it is very easy to use and almost every operator can work with it. In 1992 the dehusking mechanism was redesigned. The path of the dehusking blade was kinematically designed to move closer to the hard shell of the nut. This inturn gives better dehusking action. Another parts of the machine was also modified in order to allow smooth action.

MATERIALS AND METHODS

1. Design and Construction

The hydraulic coconut dehusking machine consists of three main parts, ie., the frame, the power unit including the electrical and hydraulic accessories, the lifting and dehusking mechanism.

The frame is made of steel angle bars (Figure 1 and plate 1). It is the welded construction. It is portable because it has steerable wheels.

Design in Holland
at the
factory

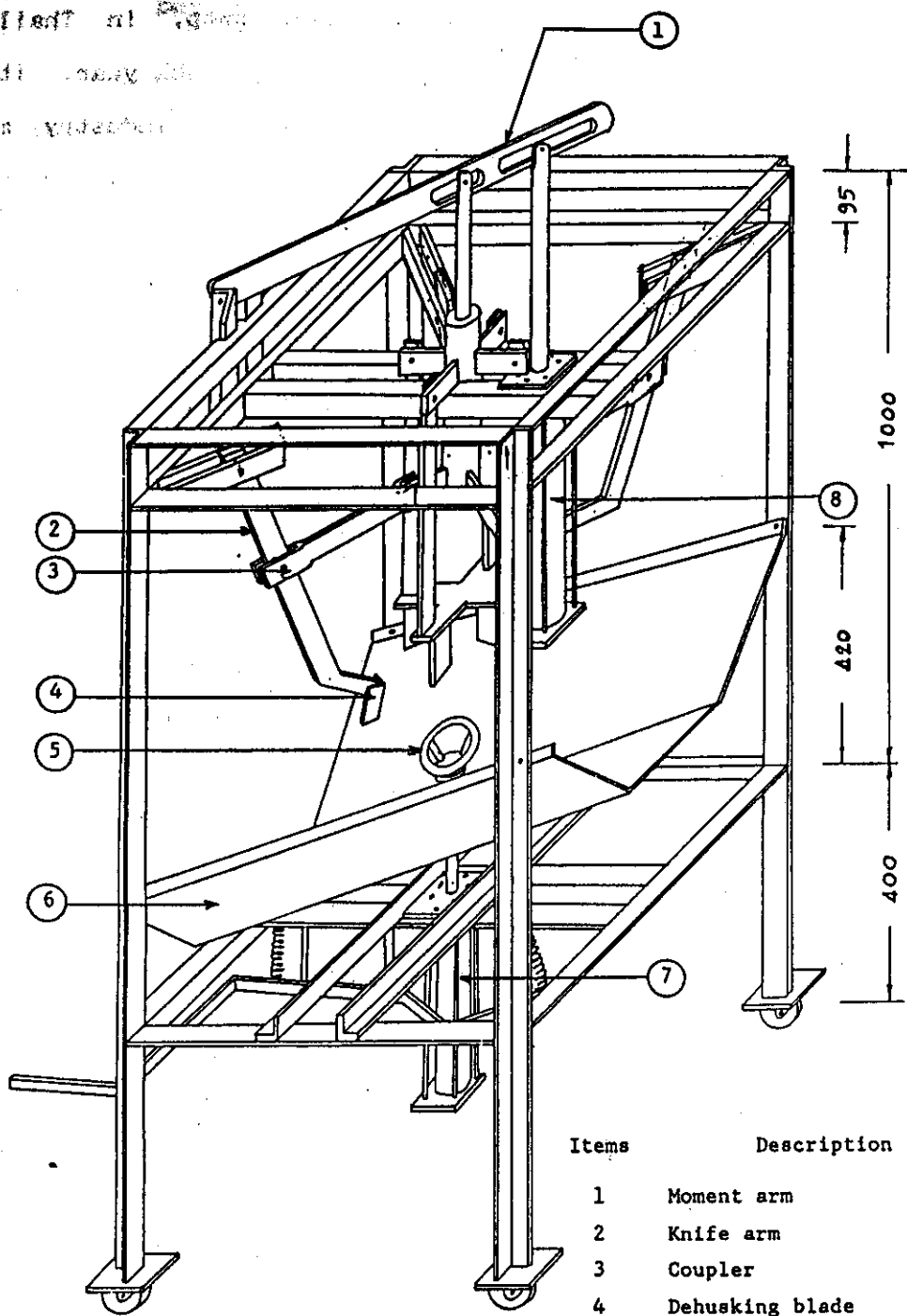

Figure 1. The automatic hydraulic dehusking machine

Items	Description
1	Moment arm
2	Knife arm
3	Coupler
4	Dehusking blade
5	Lifting pan
6	Nuts' pan
7	Lifting cylinder
8	Dehusking cylinder

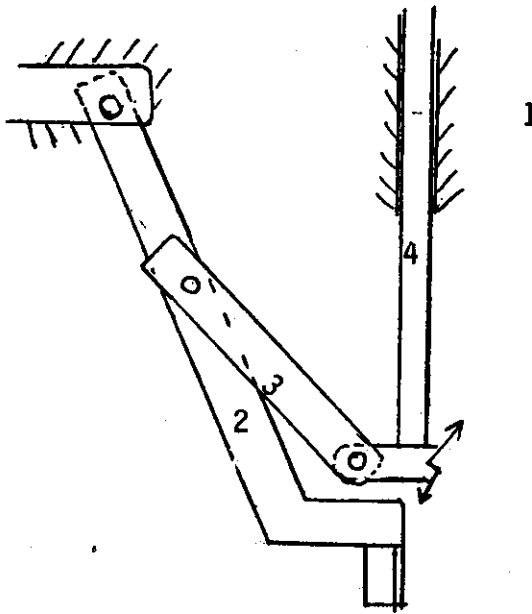

Figure 2. Kinematic diagram of the dehusking mechanism. Link 1 is the frame, link 2 is the knife arm, link 3 is the coupler, link 4 is the slider which is moved in rectilinear translation motion.

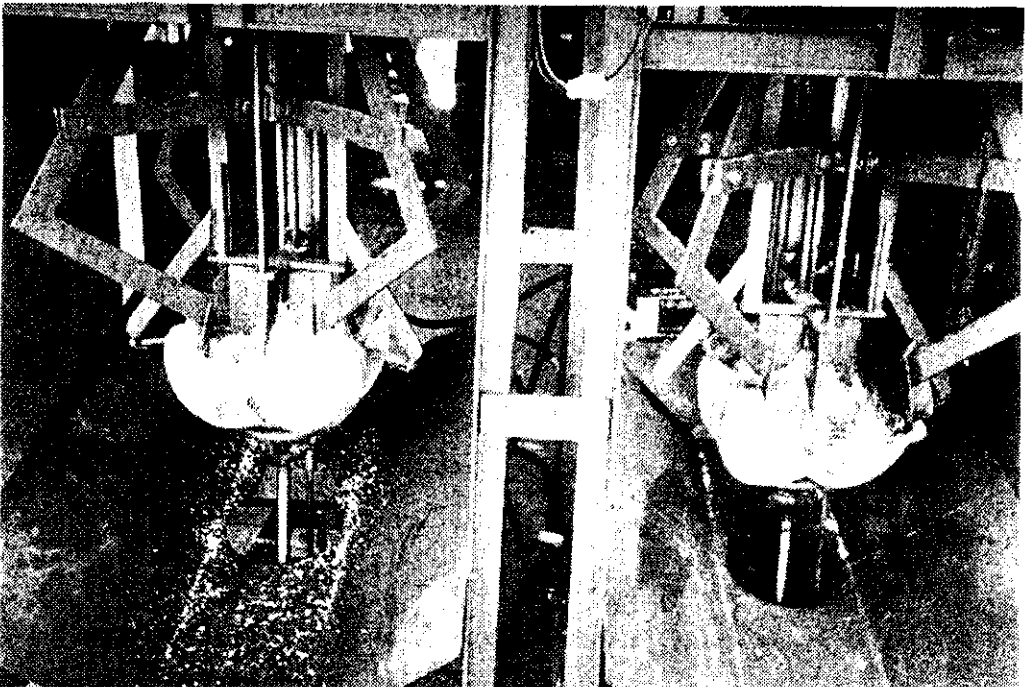

Plate 1. The automatic hydraulic coconut dehusking machine.

The power unit including the electrical and hydraulic accessories combining together as the control unit. An electric motor 220v 1.5 kW is used for driving a hydraulic pump running at a speed of 1470 rpm and deliver 14.2 liters/minute oil under 70 Kg/cm² pressure. A three position four way valve solenoid operated with spring centered is used as a directional control valve. A reducing valve is used for limiting the oil pressure before going into the lifting cylinder and operate the lifting mechanism. A sequence valve is also used for controlling oil going into the dehusking cylinder to operate the dehusking mechanism. A pressure relief valve is provided for limiting the maximum system pressure. The electrical component consists of micro switches, a magnetic contactor and a breaker switch.

The mechanism of the coconut dehusking machine is the most important part in design and construction. There are two sets of mechanism working synchronously, a lifting mechanism and a dehusking mechanism. The lifting mechanism will lift vertically up the coconut. It is powered by the lifting cylinder. It moves in rectilinear translation motion.

The dehusking mechanism infact is a kind of four bar linkage mechanism (Figure 2). Link 1 is the frame, link 2 is the knife arm, link 3 is the coupler, link 4 is the shaft which is constrained to move up and down in rectilinear translation. There are four sets of dehusking blade, each of them is welded to an individual knife arm. The shaft is lifted up by the dehusking cylinder via the moment arm this inturn will actuate the couplers and push the knife arms away from the original position. The coconut fibrous is pull out from the nut's shell by the dehusking blades in to four parts and leave the bare nut by the end of the stroke.

2. Working Principle of the System

The dehusking system was designed to work automatically. An operator was required to put a coconut on the lifting pan. The weight of the coconut caused a switch to close. The working cycle was then started. The lifting mechanism lifted up the nut and pushed it against the holding teeth and stop moving as the hard shell just touch the holding teeth. The dehusking cylinder start moving as a subsequence step and actuated the dehusking mechanism. Four dehusking blades moved apart and pull the coconuts' fibrous, torn it in pieces. By the end of the stroke both cylinders were retracted and pull back both mechanisms to their original positions. It took 5 seconds to complete one working cycle of the system. The dehusked nut falls down on the nuts' pan. The operator then collected the dehusked nut before starting the next working cycle by putting another coconut on the lifting pan again.

Another unit of the dehusking machine can be mounted by connecting its electrical and hydraulic systems in series with the first unit. By using the same electrical and hydraulic system this twin units can be operated simultaneously (Kwangwaropas, 1992)

3. Experimentations and results

Several tests were carried out to investigate the performance of the machine;

1. Check the time consumed to complete one working cycle. Using a stop watch to count the the time; starting from the beginning of the lifting period up to the end of dehusking period and all mechanisms were returned to their original positions again. The average time consumed for one cycle was found to be 5 seconds.
2. Check the average time for continuous dehusking process with one operator. The average time for continuous dehusking was 11.0 seconds per one coconut.

3. Test the maximum permissible pushing force against the hard shell of the coconut. This test was carried out by first preventing the oil flow into the dehusking cylinder. Adjust the pressure reducing valve until the oil pressure from the reducing valve (which is to be supplied for the lifting cylinder) reached 20 Kg/cm^2 . Next, put a coconut on the lifting pan and started the machine. The nut was pushed up and seized by the holding teeth. Slowly increased the oil pressure of the lifting cylinder until the hard shell of the coconut was broken. The average breaking pressure of the coconut was about 520 psi or about 35.3 Kg/cm^2 . This indicated that the coconut shell could resist against the pushing force as high as 444 Kilograms. However, if the holding teeth was smaller, the breaking pressure was also reduced (Kwangwaropas, 1991).
4. The quality of dehusking work was improved comparing with the first invented machine (Kwangwaropas, 1991). The fibrous was taken out from the nuts' shell by the machine almost completely. This can save very much time and labour. However, if the hard shell was thin and brittle, it might be broken during dehusking process.
5. Connect another set of the coconut dehusking machine to the unit. Operate both units simultaneously using two operators, one for each individual unit. The average continuous dehusking speed was 22.2 second per two coconuts.

CONCLUSIONS

The automatic hydraulic coconut dehusking machine is suitable for dehusking thick and strong hard shell coconuts. With two operators, the continuous dehusking speed was about 22.2 seconds per two coconuts. The actual power consumption is about 1.5 Kilowatts-hour per hour of operation. The dehusking process is easy and clean, less noisy and can be done anywhere. It has high potential in solving problem of dehusking labour shortage, especially during the peak period.

REFERENCES

1. Mongkol Kwangwaropas. 1991. Design, Manufacturing and Testing of the Hydraulically Operated Coconut Dehusking Machine. The Kasetsart Journal, volume 25 No 2, page 219 - 233.
2. Mongkol Kwangwaropas. 1992. Development and Improvement of the Hydraulic Coconut Dehusking Machine. The Kasetsart Journal, volume 26 No.4, page 400-408.