

UTILISATION OF COCONUT PITH FOR BIOGAS PRODUCTION

T. Vidhan Singh, A.C.Mathew, S.J.D.Bosco and K.G.N. Swamy

Central Plantation Crops Research Institute, Kasaragod, Kerala, India.-671124

ABSTRACT

Biogas production from cowdung is well studied. Coconut pith is a highly lignocellulosic material and contains lignin and cellulose in equal quantities and is rich in potash & micronutrients such as Fe, Mn, Zn & Cu. The possibility of utilizing pith for biogas production was studied in the field using 5 Nos 2m³ Khadi and Village Industries design biogas plants. The daily production of biogas in different treatments was monitored. In all the treatments, the production was found to be varying from day to day. The pattern was similar in control and second treatment. The production was less in other treatments. It was observed that when temperature is more than 33°C, the production of gas is constant. Similarly the gas production is low when the temperature falls below 30°C. It was seen that the exponential curve is the best fit for the data in the first replication. Since sufficient data points corresponding to lower temperature was not available in second replication, the equations were fitted for the range 28-33°C. Also sufficient data was not available towards the lower side in the second replication and the fit was very poor. The treatment comparison were made within the temperature range 30-33°C. It was found that coconut pith in combination with cowdung gives higher methane content biogas, while alone it does not produce any gas. The best combination was found to be with 80% cowdung and 20% coconut pith. The methane percentage was about 11 % more in the treatment 80% cowdung and 20% coir pith as compared to the control where as in all the other treatments the methane percentage was lower than the control. The modified dual fuel engine installed was running with biogas and it was observed that in 8 hours of operation approximately 10m³ biogas is consumed there by saving 5 liters of diesel. For optimum biogas production the C/N ratio should be in the range of 25-30 and in the case of 80% cowdung and 20% coir pith the C/N ratio was 26.18 and in both the replications the production of gas was higher as compared to the control.

Key words: Biogas, Coir pith, Methane

INTRODUCTION

Biogas production is a microbial process. All microbes involved in biogas production grow in the absence of air (oxygen). The most important organisms are tiny bacteria. Different groups of bacteria act upon complex organic materials in the absence of air to produce biogas rich in methane. The process involves the combined action of four groups of bacteria, in four stages, in a biogas plant. The first stage is the degradation of high molecular weight substances like cellulose, starch, proteins, fats, etc., present in organic materials, into small molecular weight compounds like fatty acids, amino acids, carbon dioxide and hydrogen. This is brought about by a hydrolytic group of bacteria.

In the second stage, the end products of the first stage are converted into acetate and hydrogen by acetogens. In order to produce more acetate, a third stage is involved in which organisms known as homoacetogens convert hydrogen and simple carbon compounds produced in the first and second stages into acetate. The fourth stage is the conversion of acetate and some other simple compounds like formate, carbon dioxide and hydrogen into methane. This is brought about by a unique group of organisms known as methanogens. Methane, being lighter than air, rises out of the system and can be collected, and used for various purposes.

Feedstock: For biogas generation, generally animal and human wastes such as cow dung,

buffalo dung, urine, poultry dropping material, other livestock excreta, night-soil, etc. are used as feedstock..It is desirable to use a mixture of excreta in order to get more gas because, as compared to cattle dung(100%), the gas production is 60% from poultry droppings, 70% from goat excreta, 150% from horse dung and 250% from pig dung. In order to utilize other materials like water hyacinth, coconut pith, crop residues, forest litter, etc., research work is in progress to develop suitable designs of biogas plants. The preferred C/N ratio is 25-30 (Kandelwal *et al.*,). The high carbon to nitrogen ratio enhances acid formation whereas a low ratio increases ammonia formation and reduces gas production.

India is one of the leading countries of the world in area and production of coconuts. During 1996-97 the estimated production was 12987.500 million nuts from an area of 1.892 million hectares. The area under coconut has been steadily increasing, particularly in the traditional coconut growing area viz. Kerala, in area and production was spectacular over the decade. The husk, the shell and the copra are the useful products besides the leaves and stem which find their use in the daily life of the people of the coconut growing areas. Though the nut is considered to be the economic product, the other parts of the palm are also economically used as such or as value added products.

The coconut husk finds its noble use due to its fibrous structure and resilience. After extracting the coir, the waste material viz. the pith consisting of dust and bits of fibres of lesser length are considered and dumped on the roadside in mounds and in increasing proportions every year. The tannins that ooze out from dump yards during monsoon are considered to create environmental pollution problems. The small units produce considerable amount of coir pith which goes mainly unutilised. Present indications are that this waste material can become an important source of organic matter and an important item of export besides the coir which is now used as geo-fabric material in western countries who are more concerned about the biodegradability of the material and environmental pollution (Savitri and Khan 1994). Keeping the above points in mind this project was undertaken to utilize coir pith for the production of biogas.

MATERIALS AND METHODS

5 numbers of 2m³ KVIC model biogas plants was constructed using granite blocks. The drum of the plant is made up of reinforced plastic. Coir pith was collected from nearby retting centre at Kasaragod. This was sieved using chicken mesh to remove long fibres present. This was then heaped near the biogas plants. Cowdung was available at the Agronomy unit of Central Plantation Crops Research Institute and from nearby areas. Initially, cowdung and coirpith of the following combinations is mixed in a mechanical mixer designed and developed using a 3 hp, 3 phase electrical motor, a reduction gear box with output rpm of 10 for proper mixing of coir pith and cowdung. The out put is connected to all the five biogas plants through 2" pipe for direct delivery of mixture to the plants. This unit was placed over a round cement tank of 1.2m diameter and depth about 0.94m. Initially, cowdung and coir pith is put in the required ratio on volume basis and water is added in the ratio of 1:1 (i.e, cowdung + coirpith : water). The experiment was conducted in randomised block design with two replications and the following combinations was used in the study.

- (i) 100% cowdung [control]
- (ii) 80% cowdung and 20% coir pith
- (iii) 60% cowdung and 40% coir pith
- (iv) 40% cowdung and 60% coir pith
- (v) 20% cowdung and 80% coir pith

Individual biogas plant gas output was connected to individual gas flow meters for

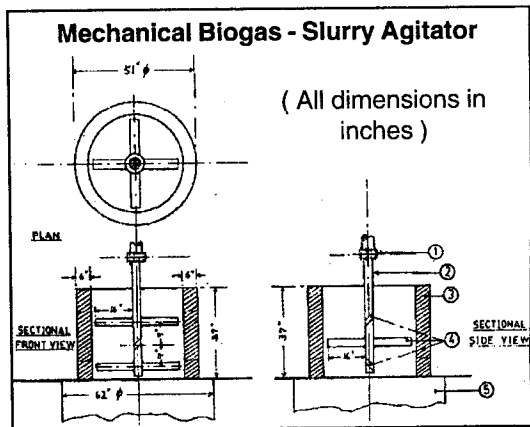

monitoring the quantity of gas produced on per day basis. The output of all the five biogas plants was then connected to a single pipe which was connected to a 5 hp dual fuel engine. The gas flow was utilised to test the efficiency of biogas run engines. Analysis of variance was performed on average daily production of biogas for the comparison of treatments. The bio-gas produced was analysed for the percentage of methane by gas chromatographic method. Gas samples were collected at random after the initial retention period of 30 days and the percentage methane obtained in two replications is presented in Table 1&2. The above trial was conducted 2 times, i.e., first replication from March 1996 to October 1996 & second replication trial from January 1998 to June 1998. The gas production was monitored on daily basis using individual gas flow meters. Quantity of biogas produced for 150 days were obtained.

RESULTS AND DISCUSSION

The chemical composition of coir pith shows that it contains 77.7 % of volatile solids. As the volatile solids of organic matter can be considered as the amount of solids actually converted by bacteria, pith can be used for biodigestions to produce methane. The volume of gas produced from pith alone is very less as compared to that with cowdung and pith. This is because pith is a lignocellulosic material and is resistant to easy degradation (Radhika *et al.* 1994). The amount of biogas produced from cowdung slurry varied even during different months having same temperature on some days confirming the importance of dung, the chemical composition of which varies with the age of the animal. As such cowdung of same batch was mixed with coir pith everyday to reduce the influence of dung quality on production of gas on all the treatments. It is a known fact that for optimum biogas production of gas the C/N ratio should be in the range of 25-30 and in the case of 80% cowdung and 20% coir pith the C/N ratio was 26.18 and in both the replications the production of gas was higher as compared to the control. This is in agreement with the work done by Hills, 1980 who showed that the optimum non-lignin carbon to nitrogen ratio should be between 25-30. The daily production of biogas in different treatments are

depicted in graphs (Fig.1-5). In all the treatments, the production was found to be varying from day to day. The pattern was similar in control and second treatment. The production was less in other treatments. Analysis of variance of average daily production showed that the treatments are significantly different. The treatment means is given in Table -3. It was observed that the treatment with 80% cowdung and 20% coir pith is on par with the control (100% Cowdung.). This treatment has produced more gas than the control in absolute term. The biogas production in other three treatments were significantly lower than the control. It was observed that the biogas production is influenced by the temperature. The relationship between temperature and production of biogas in different treatments is shown in Figs.6-10. It was observed that when temperature is more than 33°C, the production of gas is constant. Similarly the gas production is low when the temperature falls below 30°C. It was seen that the exponential curve is the best fit for the data in the first replication. Since sufficient data points corresponding to

Table 1. Methane percentage of 5 samples from 5 plants with different combinations of coconut pith & cowdung. (Replication-1)

Sl No.	Constituent	% Methane (Average of 5 samples)
1.	100% Cowdung	60.2
2.	80% cowdung+20% coir pith	71.4
3.	60% cowdung+40% coir pith	59.6
4.	40% cowdung+60% coir pith	57.4
5.	20% cowdung+80% coir pith	55.3

Table 2. Methane percentage of 5 samples from plants with different combinations of coconut pith cowdung. (Replication-2)

Sl No.	Constituent	% Methane (Average of 5 samples)
1	100% Cowdung	57.1
2	80% cowdung+20% coir pith	68.3
3	60% cowdung+40% coir pith	59.2
4	40% cowdung+60% coir pith	55.3
5	20% cowdung+80% coir pith	53.8

Table 3. Average production of biogas in different treatments

Treatment	Average production (Lit/Day)	
	For the entire experiment	For the range of temp. 30-33°C
100 % Cowdung	879.23	933.85
80 % cowdung + 20 % coir pith	929.61	970.35
60 % cowdung + 40 % coir pith	653.74	708.45
40 % cowdung + 60 % coir pith	438.06	460.80
20 % cowdung + 80 % coir pith	332.32	332.45
C.D.(5%)	86.69	131.50
C.V.(%)	4.84	6.95

lower temperature was not available in second replication (Fig.6b-10b), the equations were fitted for the range 28-33°C. Also sufficient data was not available towards the lower side in the second replication and the fit was very poor. The treatment comparison were made within the temperature range 28-33°C (Table 3). In this case also the treatment and the control was on par. The methane percentage was about 11 % more in the treatment 80% cowdung and 20% coir pith as compared to the control where as in all the other treatments the methane percentage was lower than the control except in the second replication where in 60% cow dung and 40% coir pith produced more methane (Table-1&2). The modified dual fuel engine installed was running with biogas (Initially diesel fuel is used to start) and it was observed that in 8 hours of operation approximately 10m³ biogas is consumed there by saving 5 liters of diesel. Due to continuous operation of the engine with dual fuel the rings and piston head was damaged indicating the presence of sulphur in the gas. So the maintenance cost is higher as compared to running the engine only on diesel.

From the above replicated treatments the following conclusions are drawn. A mixture of 80% cowdung and 20% coir pith produces higher gas (11% more) as compared to the control of 100% cowdung. The temperature range of 28-33°C is best suited for the production of biogas in coastal areas. Dual fuel engine can save about 5 liters of diesel utilising 10m³ biogas in 8 hours of operation.

ACKNOWLEDGEMENTS

The principal Investigator and the co-investigators express their sincere thanks to the Coconut Development Board for the financial help extended for undertaking this work. Also the investigators express their sincere thanks to Dr.M.K.Nair, former Director, C.P.C.R.I. without whom this project funding would have been a dream. The Investigators express their sincere thanks to Dr. K.U.K.Nampoothiri, Director C.P.C.R.I. who took keen interest in the project and for getting the second and third installments released without which we would not have completed this project. I would also like to thank Dr.A.K.Upadhyaya for chemical analysis and Dr.K.Murlidharan for statistical analysis. Thanks are also due to Dr.V.Rajagopal, Head, P.B.P.H.T, and all my colleagues of technology division who have helped in completing this work..

REFERENCES

- Hills, D.J., Roberts, D.W. 1980. Livestock waste- A renewable source. proc. Int. Symp., ASAE, St. Joseph Michigan, p.92
- Radhika, L.G., Seshadri, S.K. and Mohandas, P.N. 1983. A study of biogas generation from coconut pith. Chem. Tech. Biotechnol, 189-194
- Savitri, P. and Hameed Khan, H. 1994. *Journal of Plantation Crops*. 22(1):1-18
- Khandelval, K.C. and Mahdi, S.S. 1980 Biogas Technology, A practical hand book, Vol.-I, Tata Mc Graw-Hill Publishing company Limited, New Delhi.