



Electrical Induction as Stress Factor for Callus Growth Enhancement in Plumular Explant of Coconut (*Cocos nucifera* L.)

M. Neema¹ , G. S. Hareesh², V. Aparna¹, K. P. Chandran³ and Anitha Karun¹

¹Dept. of Biotechnology, ²Dept. of Post Harvest Technology, ³Dept. of Statistics, ICAR-CPCRI, Kasaragod, Kerala (671 124), India



Open Access

Corresponding  neema.agri@gmail.com

 0000-0003-0725-2027

ABSTRACT

The study was carried out at the Biotechnology Laboratory, Division of Crop Improvement, ICAR- Central Plantation Crops Research Institute, Kasaragod during 2019–2021 to investigate the effect of electric current induction in coconut plumular callus obtained from WCT variety of coconut. Callus induction was observed when the plumules extracted from the embryo were inoculated into Eeuwens Y3 media supplemented with 16.5 mg l⁻¹ 2,4-D and 1 g l⁻¹ activated charcoal. An electrical induction set up was developed to induce minute quantity of electric current to the calli. Electric current of 1 μA and 2 μA was applied to the system continuously as well as for an interval of 1 h day⁻¹ for a month and differences in callus mass before and after treatment were observed. Callus induced with electric current of 2 μA continuously for a month had maximum weight gain followed by callus induced with 1 μA current continuously for a month. Here, anode and cathode were inserted into media and callus respectively. In other two treatments where, 1 μA and 2 μA current was inducted into callus for an interval of 1 h day⁻¹ for a month as well as in control where no current was induced significant weight gain was not observed. The study implicates the effect of electric current in cell division of plants and the results suggests that continuous application of weak electric current in range of 1 and 2 μA enhances callus growth in plumular explants of coconut and could be used as a novel strategy for callus multiplication of coconut, a monospecific crop recalcitrant to *in-vitro* culture.

KEYWORDS: Callus, coconut, electrical induction, plumule culture, stress induction

Citation (VANCOUVER): Neema et al., Electrical Induction as Stress Factor for Callus Growth Enhancement in Plumular Explant of Coconut (*Cocos nucifera* L.). *International Journal of Bio-resource and Stress Management*, 2022; 13(9), 921-927. [HTTPS://DOI.ORG/10.23910/1.2022.3126](https://doi.org/10.23910/1.2022.3126).

Copyright: © 2022 Neema et al. This is an open access article that permits unrestricted use, distribution and reproduction in any medium after the author(s) and source are credited.

Data Availability Statement: Legal restrictions are imposed on the public sharing of raw data. However, authors have full right to transfer or share the data in raw form upon request subject to either meeting the conditions of the original consents and the original research study. Further, access of data needs to meet whether the user complies with the ethical and legal obligations as data controllers to allow for secondary use of the data outside of the original study.

Funding: The research was funded with the kind support from Indian Council of Agricultural Research.

Conflict of interests: The authors have declared that no conflict of interest exists.



1. INTRODUCTION

Coconut, an important crop of the tropics provides employment to the mid and lower level economies. All part of the crop is economically important and hence coconut is referred by the name 'Kalpa Vriksha' or 'Tree of Life'. Coconut is a highly cross-pollinated crop and obtaining true to type progeny in large numbers is cumbersome. Again inefficiency in the production of seedlings for replanting also remains as an issue. Hence mass multiplication of coconut plantlets by means of *in vitro* culture was attempted. Coconut is recalcitrant to *in vitro* culture, the mass multiplication has been reported by many research groups (Buffard-Morel et al., 1992, Shirke et al., 1993, Verdeil et al., 1994, Blake and Hornung, 1995, Hornung, 1995, Chan et al., 1998, Rajesh et al., 2005, Raju, 2006, Rajesh et al., 2014, Shareefa et al., 2019, Wilms, 2021) but a viable protocol for mass multiplication is yet to come. Trials for *in vitro* culture of coconut include culture media manipulation, induction of stress to the cultures as well as utilizing molecular approaches. Stress to *in vitro* cultured tissues can be induced chemically and physically. Investigations from the past decades had revealed the role of physical factors of the *in vitro* environment (Nguyen and Kozai, 1998, George and Davies 2008, Teixeira and Dobránszki 2014, Silva and Dobránszki, 2015) in growth and development of the micro propagules. To survive the stressed conditions the plant tissues, evolve complex mechanisms (Fujita et al., 2006) that subsequently produce changes in signaling components and gene transcriptions (Long, 2011, Narayani and Srivastava, 2017). Mechanical stimuli, like vibrations, sound and ultrasound may also have morphogenetic, growth and developmental effects *in vitro* (Dobránszki, 2021).

In this study we emphasize on physical stress induction to *in vitro* grown cultures of coconut by means of electric stimulation. Plants, in response to stress induction, produce unorganized cell masses called callus. By callus induction the tissues regain their cell proliferative competence. Stress was provided to tissues to aid in their regenerative process. Effect of electric current on tobacco callus has been studied by researchers (Mordhorst and Lorz, 1992, Cogalniceanu et al., 1998, Goldsworthy, 2006). The external electric field not only causes a temporary permeabilization of the plasma membrane during electroporation and electro transformation experiments (primarily with plant protoplasts), but also affects the entire cell's metabolism, influencing the regeneration performance (Rech et al., 1987, Ochatt et al., 1988, Mordhorst and Lorz, 1992). Sing et al. (1995) had reported that power line treated water had differentially inhibited spore germination of fungi. In cabbage, micro-current intensities within the range of 0.6–2.60 μA had promoting effect on shoot differentiation

and weight gain (Xiao et al., 1993). An innate flow of electric current exists between the living cells during their growth and development. When small amount of electric current was administered, an endogenous flux was induced which had effect in tissue morphology as well as healing process. The direction of the current influences the polarity and thereby will have influence in the cell growth. When a current was artificially supplied to the growing system, it reinforced the natural current of the callus (Rathore and Goldsworthy, 1985a). In this study an effort was made to determine the effect of electric induction as a stress induction factor in callus proliferation of plumular explant of coconut, recalcitrant to tissue culture. For this an electrical induction set up was devised to induce micro amperes of current to *in-vitro* grown callus cultures of coconut.

2. MATERIALS AND METHODS

The study was carried out at the Biotechnology Laboratory, Division of Crop Improvement, ICAR-Central Plantation Crops Research Institute, Kasaragod during 2019–2021. West Coast Tall (WCT) variety of coconut was used for the study. Endosperm plugs of WCT variety of coconut were obtained by scooping out the embryo portion of coconut with a cork borer. These plugs were sterilized in 0.1% mercuric chloride for 3 m. Embryos were extracted by splitting open the plugs into 2 and were sterilized aseptically in 20% sodium hypochlorite solution for 15 minutes followed by rinsing 5–6 times with sterile distilled water until the soapy feel of sodium hypochlorite was removed. From the embryo, plumules were scooped out using sickle shaped blades and inoculated in petriplates containing Eeuwens's Y3 medium (Eeuwens, 1976) with 16.5 mg l^{-1} 2,4-D, 30 g l^{-1} sucrose, 1 g l^{-1} activated charcoal and 7 g l^{-1} agar. These cultures were incubated in dark for two months at $27 \pm 2^\circ\text{C}$ and RH 70% for callus induction. The calluses thus obtained were used for electric induction studies. The calluses were weighed before inoculating into phytajars containing 50ml of the same media with 2,4 D concentration reduced to 10 mg l^{-1} . Two perforations were made on the lid of the phytajar for the passage of electrodes. The electrodes used were polytetrafluoroethylene insulated stainless steel wires of 0.29 mm sterilized by autoclaving. One electrode was inserted for about 1.5 mm into the callus and another was inserted about 25 mm away in the medium. The wires were bent over the phytajar lids and were covered with cling film. The system was kept in dark and observations were taken after one month.

The circuit designed for the project has the following components.

2.1. Power supply

The main power supply comprised of a step-down



transformer that converts the 230 V 50 Hz AC line voltages to 15 V AC. The secondary of the transformer was connected to a bridge rectifier comprising of four diodes and a filter capacitor. The output of the bridge rectifier was connected to a sealed maintenance free 7 AH 12 V battery. The rectified DC supply charges the battery and provides sourcing current to the main circuit. The DC available (around 14 V) at the battery terminal was fed to a 3-pin voltage regulator IC that provides a constant, stable and regulated 9 V DC output. Visible LED indicators were provided to identify the presence of input and output power. An auxiliary regulated power supply was designed for the Monitoring circuit without power backup as the 3 ½ digit LCD micro ammeter required isolated power supply.

2.2. Resistor

A high value user adjustable resistor network was provided to limit and adjust the current flow through the samples. For a current flow of 1 µA to pass through the circuit (assuming the path was purely resistive), the resistance required was calculated (as per Ohm’s Law).

As per Ohm’s law,

$$V=IR..... (1)$$

In the study,

$$I=1 \mu A \text{ and } 2 \mu A$$

$$V=9V$$

$$R=9 M\Omega \text{ and } 4.5 M\Omega \text{ (respectively)}$$

As the medium and tissue samples are found to impose some additional resistance in the circuit (ranging from 1–3 M Ω), the resistance that required for the desired current flow will be less than the calculated values as above. During the experiment, the values of resistors used in the circuit varied from 5.5–6.5 M Ω for 1 µA and 3.3–4.4 M Ω for 2 µA circuits.

The current flow path was designed and wired with high precision fixed carbon film resistors having least tolerances. It was found that with growth of the tissue, the resistance increased and there occurred changes in the set value of current. To compensate this, instead fixed value resistance, a high value variable resistor (preset) was introduced in the circuit to fine tune the current flow. The user can rotate the preset to get the desired value of current, if change is observed.

2.3. Monitoring cum bypass circuit

A monitoring cum bypass circuit to monitor the current flow in each channel as well as bypassing the monitoring circuit using switches. As the system deals with very minute currents in the range of micro amperes, to reduce the complexity, unwanted current loops, contact problems and size of the control unit, the circuit was designed with a single

micro ammeter and high-quality low contact resistance switches and connectors for all channels. Separate switching control was designed for each channel by using two types of switches. A toggle switch (Figure 1) with three states (ON-OFF-ON) and one 12-way SP12T rotary switch were used in the design. With these, two modes of operation of the circuit are possible - monitoring mode and bypass mode.

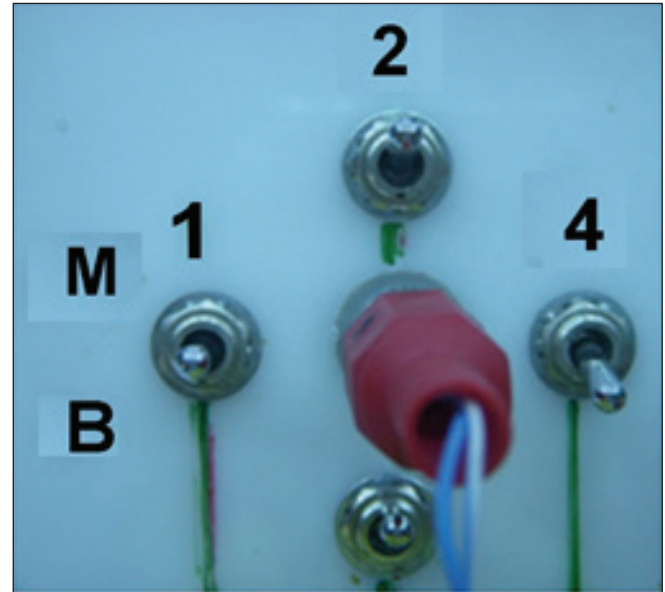

Figure 1: Toggle switch states, Ch.1- OFF, Ch.2 in Monitoring mode, Ch. 4 Bypass mode, M: Monitoring B: Bypass (Ch. – channel)

2.4. Current display

A micro ammeter was used to display the real time current flow in monitoring mode. A pre calibrated 3 ½ digit LCD based micro ammeter operating in the range 0–20 µA was used in the circuit to measure the current flow through channels.

Two sets of control circuits were designed and setup for exposing the sample tissues to current flow (Figure 2, 3 and 4). One was subjecting the callus tissues for a magnitude of 1 µA and 2 µA for 1 h day⁻¹ for 20 channels for each current. The other one was subjecting the tissues for a magnitude of 1µA and 2 µA continuously for one month for 20 channels

2.5. The treatments

The experiment was conducted in Completely Randomized Design (CRD) with twenty replications (Figure 5 and 6). Stainless Steel electrodes are inserted to the callus tissue and the media (Figure 7). One way analysis of variance (ANOVA) was carried out in SAS Ver.9.3. Statistical significance of the differences of the treatment means were assessed employing Tukeys HSD at 5% level of significance. The different treatments of the study are subjecting the callus tissues to a magnitude of 1 µA (T₁) and 2 µA (T₂)

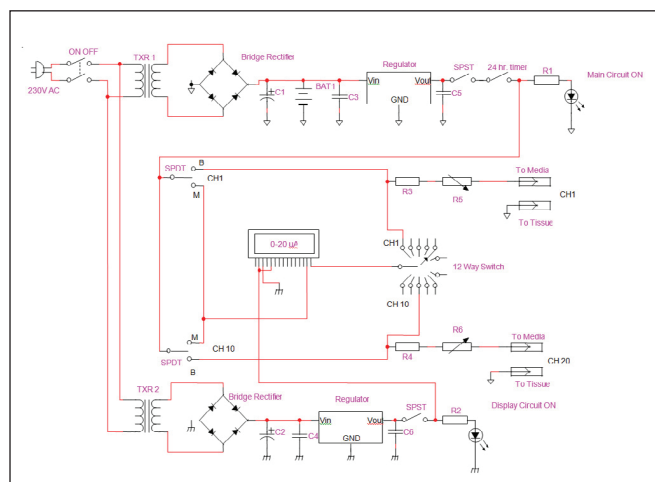

Figure 2: Schematic circuit for 1 $\mu\text{A h}^{-1} \text{ day}^{-1}$ and 2 $\mu\text{A h}^{-1} \text{ day}^{-1}$ current flow

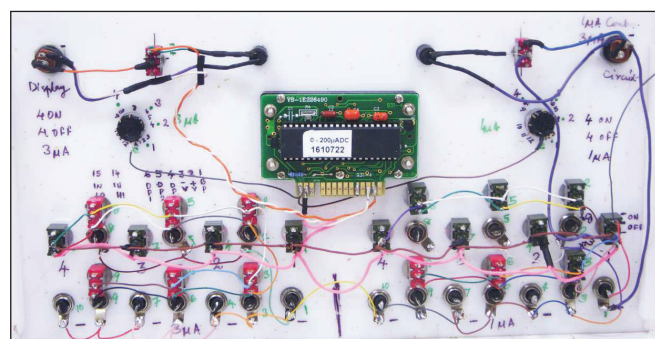

Figure 3: View of the internal connection between the hardware components for 20 channels

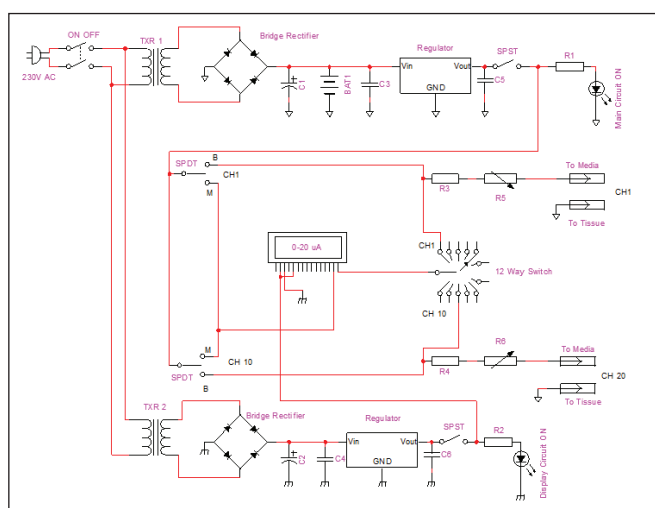

Figure 4: Schematic circuit for the 1 and 2 μA current flow continuously

current 1 h day⁻¹ as well as continuously (T₃ – 1 μA and T₄ – 2 μA) for a period of one month for 20 channels. In the control treatment, the two electrodes were inserted to the callus and medium, but no current was induced.



Figure 5: Experiment setup – 1 μA for 20 channels

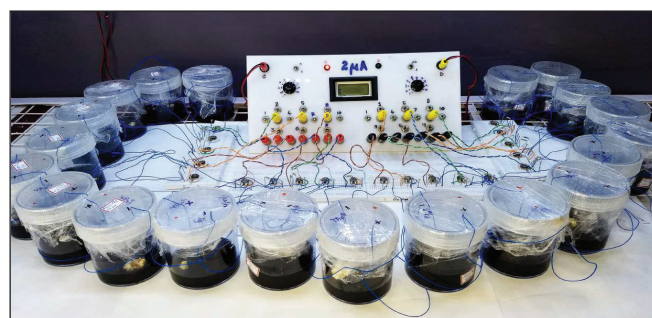

Figure 6: Experiment setup – 2 μA for 20 channels

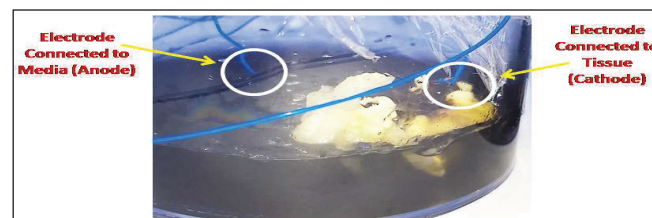

Figure 7: Stainless Steel electrodes are inserted to the callus tissue and the media

3. RESULTS AND DISCUSSION

The plumular callus of WCT variety of coconut was subjected to an electric current of 1 μA and 2 μA at the rate of 1 hr day⁻¹ as well as continuously throughout the day for 1 month. The initial weight of the callus as well as the final weight of the callus was recorded. The mean difference in weight was recorded (Table 1). Analysis of variance showed that there exists statistically significant difference among the treatments at 5% level of significance. Further the multiple comparison of treatment means indicate that the treatment T₄ (Application of 2 μA current continuously throughout the day for a month) had resulted in the highest increase in callus weight which was significantly different from all other treatments. The treatments T₁ (application of 1 μA current @ 1 h day⁻¹) and T₂ (application of 2 μA current @ 1 h day⁻¹) were not significantly different from the control. Even though the treatment T₃ (application of 1 μA current continuously) was significantly different from the other treatments (Table 1) the mean difference in weight was highest in T₄.

Experiments on the electro-stimulation of plants date back to Maimbray in 1746 (Goldsworthy, 1996) but the effect of electric induction in *in vitro* culture of plants started

Table 1: Effect of electric current in callus induction

Treatments	Mean difference in weight
Control	0.15 ^C
T ₁	0.06 ^C
T ₂	0.24 ^C
T ₃	0.73 ^B
T ₄	2.03 ^A

only from Rathore and Goldsworthy (1985a). Studies have shown that a certain level of stimulation had occurred in the growth of the plants exposed to strong electric fields which led to the development of a particular type of cultivation named 'electroculture', where plants were grown under wires carrying high voltages (Blackman et al., 1923, Blackman, 1924, Blackman and Legg, 1924). The innate electric current flowing through the living system was important for the development and wound regeneration in plants and animals (Tyler, 2017). Researchers has observed that certain bioelectric events act as instructive signals that enables the coordination of cell behaviors to consistent patterning programs. For example, the lateral root emergence was preceded by a change in electric potential in *Phaseolus angularis* (Hamada et al., 1992). A trans membrane voltage potential in the order of -50mV was obtained by the flow of charges achieved by ion fluxes through ion channels that are linked to specific domains of the cells (McCaig et al., 2009). The right cells along with the right supporting molecule should be present at the appropriate time and place for specific cell level and tissue level function to happen. Here the externally supplied electric current acted as a facilitator for the cell division. When an electric current was given to a system, cell surface membrane proteins confines to form a patch and acted as the centre point for the development of cytoplasmic microfilaments and microtubules. These microtubules orient the secretion of cell wall precursors and also acts as skeletal basis of spindle and phragmoplast during cell division and through the preprophase band determine the plane of cell division (Trewavas, 1982).As in the case of regeneration (Tyler, 2017) in callus formation also there might me the re-institution of the innate electric flux that was present at the time of morphogenesis. The tissues exposed to weak electric current, alternating (Cogalniceanu et al., 2000) as well as direct (Rathore& Goldsworthy, 1985a,) had resulted in efficient *in-vitro* regeneration of tobacco tissues. Similarly, in wheat also both root and shoot development was stimulated by electrical induction (Goldsworthy, 1996, Rathore and Goldsworthy, 1985b) and

the current applied at wrong conditions will be harmful and may yield non-productive output.

In this study application of 2 μ A current continuously has resulted in significant increase (Figure 8) in weight of the callus but 2 μ A current h⁻¹day⁻¹ didn't yield considerable weight gain. Again, continuous application of 1 μ A current throughout the day for a month, even though did not result in callus weight gain as much as in continuous application of 2 μ A current, the weight gain was significantly different from other treatments. The reason might be attributed to the fact that continuous application of electric current might had cumulative effect on the growth of the callus. An electric current of 2 μ A was optimum to stimulate the innate electric current that was flowing between the tissues. Hence the intensity as well as the duration of electric stimulus had considerable effect on the callus growth of plumular explants of coconut. The result obtained from the study have practical applications in the field of secondary metabolite production, as large-scale production of plant cells were required for the production of secondary metabolites (Janarthanam et al., 2010).

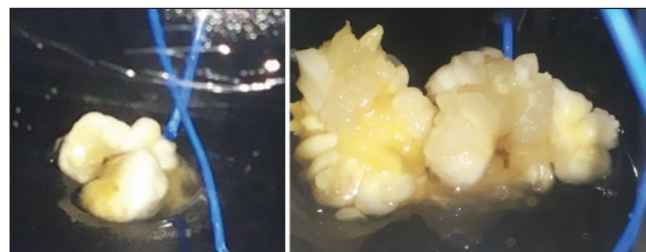

Figure 8: Increase in callus growth from initial inoculation (A) to one month after treatment (B) in T₄

4. CONCLUSION

The duration and intensity of the electric current administered to the callus tissue had significant effect on callus weight. Among treatments, induction of 2 μ A electric current continuously for one month increased callus weight of coconut plumular explants. The callus weight gain could be attributed to the enhancement of cell division by passage of electric current. The finding is significant in fields where large quantity of callus is required like in secondary metabolite production.

5. ACKNOWLEDGEMENT

The authors acknowledge Indian Council of Agricultural Research for providing the necessary funds required for carrying out the study.

6. REFERENCES

- Blackman, V.H., 1924. Field experiments in electro-culture. The Journal of Agricultural Science 14(2), 240-267.
Blackman, V.H., Legg, A.T., 1924. Pot-culture experiments

- with an electric discharge. *The Journal of Agricultural Science* 14(2), 268–286.
- Blackman, V.H., Legg, A.T., Gregory, F.G., 1923. The effect of a direct electric current of very low intensity on the rate of growth of the coleoptile of barley. *Proceedings of Royal Society of London B* 95(667), 214–228.
- Blake, J., Hornung, R., 1995. Somatic embryogenesis in coconut (*Cocos nucifera* L.). In: Jain, S., Gupta, P., Newton, R. (Eds.). *Somatic embryogenesis in woody plants*. Kluwer, Dordrecht, The Netherlands, 327–349.
- Buffard-Morel, J., Verdeil, J.L., Pannetier, C., 1992. Embryogenesesomatique du cocotier (*Cocos nucifera* L.) a partir de tissusfoliaires: Etude histologique. *Canadian Journal of Botany* 70(4), 735–741.
- Chan, J.L., Saenz, L., Talavera, C., Hornung, R., Robert, M., Oropeza, C., 1998. Regeneration of coconut (*Cocos nucifera* L.) from plumule explants through somatic embryogenesis. *Plant Cell Reports* 17, 515–521.
- Cogalniceanu, G., Radu, M., Fologea, D., Brezeanu, A., 2000. Short high-voltage pulses promote adventitious shoot differentiation from intact tobacco seedlings. *Electromagnetic Biology and Medicine* 19(2), 177–187.
- Cogalniceanu, G., Radu, M., Fologea, D., Moiso, N., Brezeanu, A., 1998. Stimulation of tobacco shoot regeneration by alternating weak electric field. *Bioelectrochemistry and Bioenergetics* 44(2), 257–260.
- Dobránszki, J., 2021. Application of naturally occurring mechanical forces in *in vitro* plant tissue culture and biotechnology. *Plant Signaling & Behavior* 16(6), 1902656.
- Eeuwens, C.J., 1976. Mineral requirements for growth and callus initiation of tissue explants excised from mature coconut palms (*Cocos nucifera*) and cultured *in vitro*. *Physiologia Plantarum* 36(1), 23–28.
- Fujita, M., Yasunari, F., Yoshiteru, N., Fuminori, T., Yoshihiro, N., Kazuko, Y.S., Kazuo, S., 2006. Crosstalk between abiotic and biotic stress responses: a current view from the points of convergence in the stress signaling networks. *Current Opinion in Plant Biology* 9(4), 436–442.
- George, E.F., Davies, W., Effects of the physical environment. 2008. In: George, E.F., Hall, M.A., De Klerk, G.J. (Eds.), *Plant propagation by tissue culture*. Springer, Dordrecht, 423–464.
- Goldsworthy, A., 1996. Electrostimulation of cells by weak electric currents. In: Lynch, P.T., Davey, M.R. (Eds.), *Electrical Manipulation of Cells*. Springer, Boston, MA, 249–272.
- Goldsworthy, A., 2006. Effects of electrical and electromagnetic fields on plants and related topics. In: Volkov, A.G. (Ed.). *Plant Electrophysiology*. Springer, Berlin, Heidelberg, 247–267.
- Hamada, S., Ezaki, S., Hayashi, K., Toko, K., Yamafuji, K., 1992. Electric current precedes emergence of a lateral root in higher plants. *Plant Physiology* 100(2), 614–619.
- Hornung, R., 1995. Micropropagation of *Cocos nucifera* L. from plumular tissues excised from mature zygotic embryos. *Plantations, Recherche, Developpement (France)* 50, 38–41.
- Janarthanam, B., Gopalakrishnan, M., Sekar, T., 2010. Secondary metabolite production in callus cultures of *Stevia rebaudiana* Bertoni. *Bangladesh Journal of Scientific and Industrial Research*, 45(3), 243–248.
- Long, T.A., 2011. Many needles in a haystack: Cell-type specific abiotic stress responses. *Current Opinion in Plant Biology* 14(3), 325–331.
- McCaig, C.D., Song, B., Rajnicek, A.M., 2009. Electrical dimensions in cell science. *Journal of Cell Science* 122(23), 4267–4276.
- Mordhorst, A.P., Lorz, H., 1992. Electro-stimulated regeneration of plantlets from protoplasts derived from cell suspension of barley (*Hordeum vulgare*). *Physiologia Plantarum* 85(2), 289–294.
- Narayani, M., Srivastava, S., 2017. Elicitation: A stimulation of stress in *in vitro* plant cell/tissue cultures for enhancement of secondary metabolite production. *Phytochemistry Reviews* 16(6), 1227–1252.
- Nguyen, Q.T., Kozai, T., 1998. Environmental effects on the growth of plantlets in micropropagation. *Environment Control in Biology* 36(2), 59–75.
- Ochatt, S.J., Chand, P.K., Rech, E.L., Davey, M.R., Power, J.B., 1988. Electroporation-mediated improvement of plant regeneration from colt cherry (*Prunus avium* × *Pseudocerasus*) protoplasts. *Plant Science* 54(2), 165–169.
- Rajesh, M.K., Radha, E., Sajini, K.K., Karun, A., 2014. Polyamine-induced somatic embryogenesis and plantlet regeneration *in vitro* from plumular explants of dwarf cultivars of coconut (*Cocos nucifera* L.). *Indian Journal of Agricultural Sciences* 84(4), 527–530.
- Rajesh, M.K., Radha, E., Sajini, K.K., Karun, A., Parthasarathy, V.A., 2005. Plant regeneration through organogenesis and somatic embryogenesis from plumular explants of coconut (*Cocos nucifera* L.). *Journal of Plantation Crops* 33, 9–17.
- Raju, C.R., 2006. Direct *in vitro* shoot development from immature rachilla explants of coconut (*Cocos nucifera* L.). *CORD* 22(1), 51–58.
- Rathore, K.S., Goldsworthy, A., 1985a. Electrical control of



- growth in plant tissue cultures. *Nature Biotechnology* 3(3), 253–254.
- Rathore, K.S., Goldsworthy, A., 1985b. Electrical control of shoot regeneration in plant tissue cultures. *Nature Biotechnology* 3(12), 1107–1109.
- Rech, E.L., Ochatt, S.J., Chand, P.K., Power, J.B., Davey, M.R., 1987. Electro-enhancement of division of plant protoplast-derived cells. *Protoplasma* 141(2–3), 169–176.
- Silva, J.A.T., Dobránszki, J., 2015. How do magnetic fields affect plants *in vitro*. In *Vitro Cellular & Developmental Biology - Plant* 51, 233–240.
- Shirke, S.V., Kendurkar, S.V, Apte, A.V, Phadke, C.H., Nadgauda, R.S., Mascarenhas, A.F., 1993. Regeneration in coconut tissue culture. In: Nair, M.K. (Ed.), *Advances in Coconut Research and Development*. Oxford & IBH Publ. Co Pvt Ltd, New Delhi, 235–237.
- Singh, U.P., Rai, S., Singh, S., Singh, P.K., 1995. Effect of 50-Hz-powerline-exposed water on spore germination of some fungi. *Electro- and Magnetobiology* 14(1), 41–49.
- Teixeira da Silva, J.A., Dobranszki, J., 2014. Sonication and ultrasound: impact on plant growth and development. *Plant Cell, Tissue and Organ Culture* 117(2), 131–143.
- Trewavas, A., 1982. Possible control points in plant development. In: Smith, H., Grierson, D. (Eds.). *The Molecular Biology of Plant Development*. Blackwell Scientific Publications, Oxford, 7–27.
- Tyler, S.E.B., 2017. Nature's electric potential: A systematic review of the role of bioelectricity in wound healing and regenerative processes in animals, humans, and plants. *Frontiers in Physiology* 8, 627.
- Verdeil, J.L., Huet, C., Grosdemange, R., Buffard-Morel, J., 1994. Plant regeneration from cultured immature inflorescences of coconut (*Cocos nucifera* L.): Evidence for somatic embryogenesis. *Plant Cell Reports* 13(3–4), 218–221.
- Wilms, H., De Bièvre, D., Longin, K., Swennen, R., Rhee, J., Panis, B., 2021. Development of the first axillary *in vitro* shoot multiplication protocol for coconut palms. *Scientific Reports* 11(1), 1–10.
- Xiao-jia, W., Qiang, W., Ming, S., Er-xin, Z., 1993. Effects of stimulation with weak electric currents on *in vitro* culture of cabbage. *Journal of Integrative Plant Biology* 35(Suppl.). Available at <https://www.jipb.net/EN/abstract/abstract23043.shtml>.

