

Design, development and evaluation of a tractor mounted air blast sprayer for coconut and arecanut

Science Progress

2023, Vol. 106(3) 1–16

© The Author(s) 2023

Article reuse guidelines:

sagepub.com/journals-permissions

DOI: 10.1177/00368504231199927

journals.sagepub.com/home/sci

R Pandiselvam¹ , A C Mathew¹,
Syed Imran², R Thava Prakasa Pandian³
and M R Manikantan¹

¹Physiology, Biochemistry and Post-Harvest Technology Division, ICAR – Central Plantation Crops Research Institute, Kasaragod, Kerala, India

²ICAR – Central Institute of Agricultural Engineering Regional Station, Coimbatore, India

³ICAR – Central Plantation Crops Research Institute (CPCRI) Regional Station, Vittal, Karnataka, India

Abstract

A tractor mounted air blast sprayer was designed and developed to reduce the drudgery involved in the manual spraying of pesticide by climbing coconut tree. The sprayer mounted on a small tractor, prime mover, is operated by the power taken from its power take off (PTO). In this study, the influence of two important parameters viz., blower speed (2250 and 3000 rpm) and tractor speed (1.5 and 2.5 km h⁻¹) at different heights on the spray characteristics such as volume mean diameter (VMD), droplet density, and spray deposition were collected and analysed. The tractor speed of 1.5 kmh⁻¹ and blower speed of 3000 rpm was observed at recommended VMD between 100–200 µm at a height above 21 m. Hence, the tractor speed of 1.5 kmh⁻¹ and blower speed of 3000 rpm was selected for field evaluation. The mean height of the coconut tree in the tested field was 24 m. The mean droplet size and deposition were observed at 124 µm and 7.2 µl cm⁻², respectively at 24 m height. The effective field capacity, field efficiency, and fuel consumption were 0.524 ha.h⁻¹, 73.72%, and 4.67 l h⁻¹, respectively.

Keywords

Spraying, pesticide, droplet size, deposition, air-assist sprayer, plantation crops

Corresponding authors:

R. Pandiselvam Physiology, Biochemistry and Post-Harvest Technology Division, ICAR – Central Plantation Crops Research Institute, Kasaragod, 671 124, Kerala, India.

Emails: anbupandi1989@yahoo.co.in; r.pandiselvam@icar.gov.in

M. R. Manikantan, Physiology, Biochemistry and Post-Harvest Technology Division, ICAR – Central Plantation Crops Research Institute, Kasaragod, 671 124, Kerala, India.

Email: manicpcr@gmail.com



Creative Commons Non Commercial CC BY-NC: This article is distributed under the terms of the Creative Commons Attribution-NonCommercial 4.0 License (<https://creativecommons.org/licenses/by-nc/4.0/>)

which permits non-commercial use, reproduction and distribution of the work without further permission provided the original work is attributed as specified on the SAGE and Open Access page (<https://us.sagepub.com/en-us/nam/open-access-at-sage>).

Introduction

Coconut is one of the commercial value agricultural products in India. Coconut pest infestation is a serious challenge to farmers. If proper precaution is not taken, pest infestation increases in coconut farms and this may eventually lead to loss of trees even.¹ Severe pest infestation may decrease coconut production and reduce the chances of recovery of coconut trees. Timely application of pesticide/ insecticide material is an important factor in coconut cultivation. Some farmers use bio-agents to control coconut pests organically. Spraying is usually done manually by climbing the tree. However, this method shows less effective in pest control and is a labor-intensive operation. At present, the availability of tree climbers is reduced drastically because of the drudgery involved in the operation. Severe injuries, even fatalities, of tree climbers due to falling from the coconut tree while climbing are also reported. Some types of hydraulic sprayers with telescopic spraying systems were developed and evaluated in tall-tree crops like coconut, but this system has limitations such as low spraying height, low accuracy, and less effectiveness in control of pest attack.²

Pesticide application is a complex process where uniformity of spray deposition is mainly influenced by target canopy characteristics, type of spray equipment and mode of operation and properties of spray chemical.³ Air-assisted spraying techniques are considered one of the best pesticide applications for orchard crops. An air-assisted spraying system could improve the pesticide deposit levels and the coverage rate on leaves, increase the penetration of the spray droplets into the canopy and reduce the spray loss.⁴ Many tractor operated air-assisted sprayers were developed for the height of 15 m for better deposition and coverage of pesticide throughout the canopy^{5,6} but very limited work has been reported in the air assisted sprayers above 15 m for tall crops like coconut field.⁷⁻⁹ Arecanut (*Areca catechu* L.) is a profitable plantation crop widely grown in India and Tropical Asia. Fruit rot disease (*Phytophthora meadii*) plays a substantial role in the reduction of palm productivity. Manual spraying of fungicides against fruit rot is unsafe, especially during monsoon season.

In India, only a few attempts have been made in developing sprayers for coconut and areca nuts that could be operated from the ground and could reach a height of about 25 m. Hence, an effort has been made to develop an air blast sprayer for coconut and arecanut farms to control pest infestation by improving spray deposition and spray coverage.

Materials and methods

Development of air blower

An air blower was designed to reach a height of 30 m. The air blower consists of 20 horizontal fins fixed on a circular frame. The whole unit was enclosed in a roto-molded plastic blower casing with an inlet at one side and an outlet at the top. Detailed drawings and parts of the blower are given in Figs. 1–6. The blower could blow air to a height of 30 m at a blower speed of 2250 to 3000 rpm. The air blast sprayer was developed to be attached to a small tractor with a 14.7 kW capacity. Power is taken from the PTO of a garden tractor to operate the air blower.

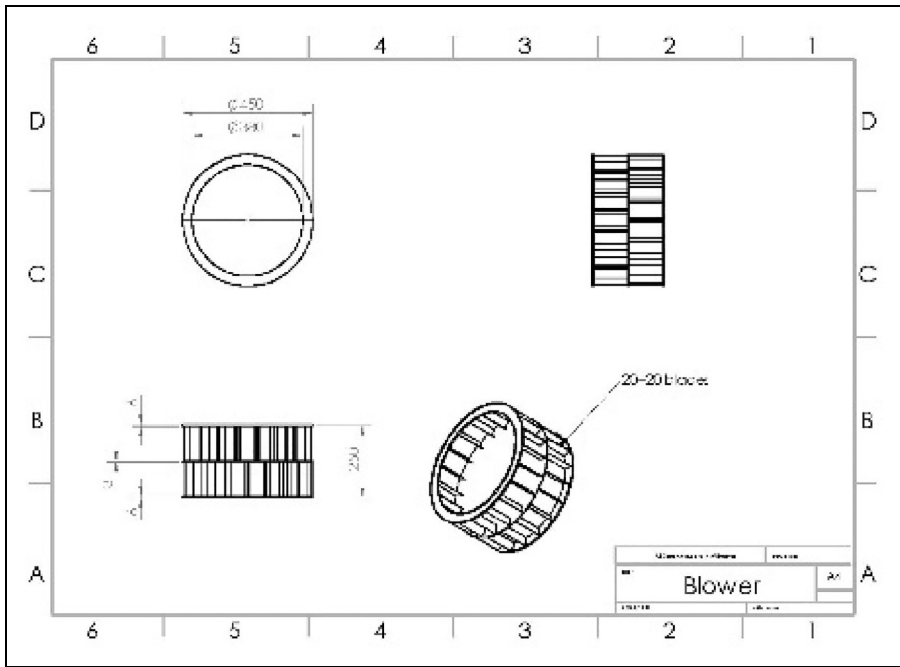

Figure 1. Impeller of blower.

Power transmission unit

A power transmission unit to transmit power from the PTO of the tractor to the blower and the chemical injection pump has been fabricated. Power is transmitted from the PTO to the blower shaft through a gearbox to attain the required speed, two gear ratios were used (1:4.18 and 1:5.5) in the present study. The chemical injection pump was directly coupled to the PTO i.e. without any gear i.e. without change in rpm.

Chemical injection pump

Two types of pumps such as positive displacement pump and centrifugal pump were tested to pump chemicals at the required height and rate. Centrifugal pumps are sturdier and require lesser maintenance compared to positive displacement pumps. However, the centrifugal pump could reach only up to a height of 1.5 m and the required discharge also could not be achieved. The positive displacement pump could inject chemicals more accurately and at a much higher elevation than the centrifugal pump and was selected. The pump gets power from the power transmission unit and rotates at the same speed as that of the tractor PTO.

Spray lance

When operated in an undulating field and also when there is drift of spray due to wind the spray needs to be directed to reach the coconut crown. A spray direction

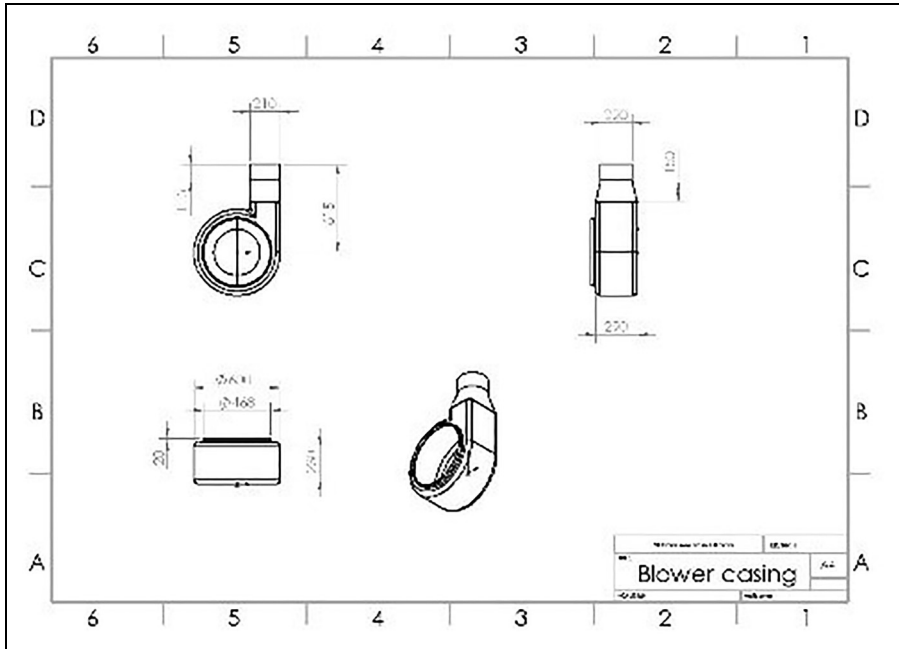

Figure 2. Blower assembly.

mechanism was designed and developed. The spray lance was made up of two parts. Each part is a pipe with a 45° bend. The two pipes were joined together using a gear and could be rotated at 360°. The lower pipe was fixed and the upper pipe was rotated to tilt the lance from 0° to 90° vertically. A DC motor was provided to rotate the upper pipe. Power for the DC motor was taken from the battery of the tractor. The direction of rotation could be reversed by reversing the polarity. Atomizer was fixed inside the upper pipe. The whole unit, lower pipe, and upper pipe with atomizer fixed inside act as the lance of the sprayer. The lance was fitted to the outlet of the blower with a gear. The lance could be rotated at 360° on a vertical axis using the gear. By rotating the lance fitted to the blower and rotating the upper portion of the lance spray can be directed to any direction and any angle from 0° to 90° vertically.

Atomization unit

The atomization unit (Fig. 7) was fixed inside the lance (Fig. 8). Insecticide/pesticide, in liquid form was pumped into the atomizer. The blower creates a strong air current inside the lance and the atomizer rotates with the help of the fins provided. The chemical comes out of the atomizer first through the bigger holes and then through a wire mesh into the strong air current. The chemical thus gets atomized and carried along with the air current.

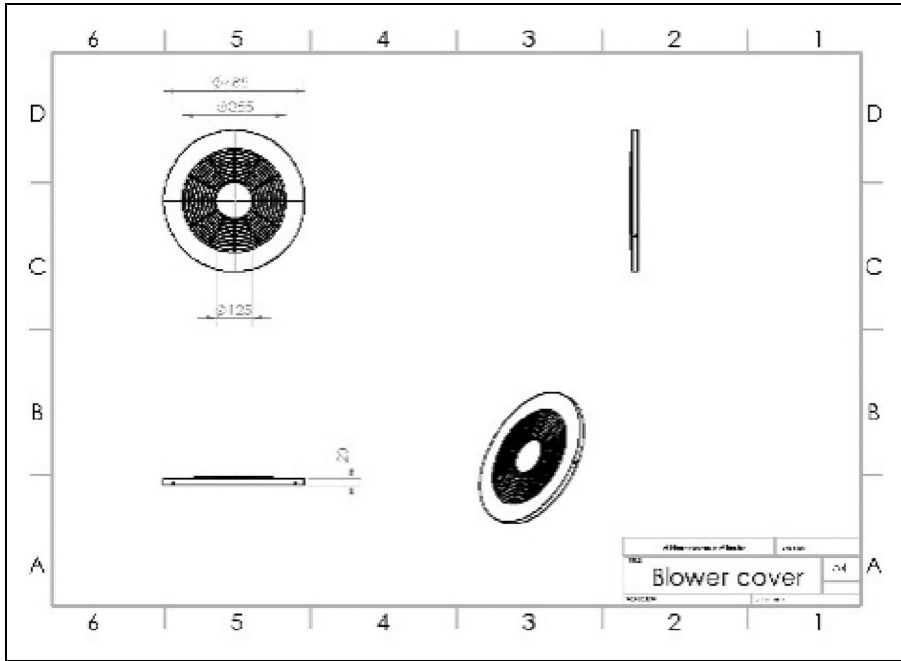

Figure 3. Inlet cover.

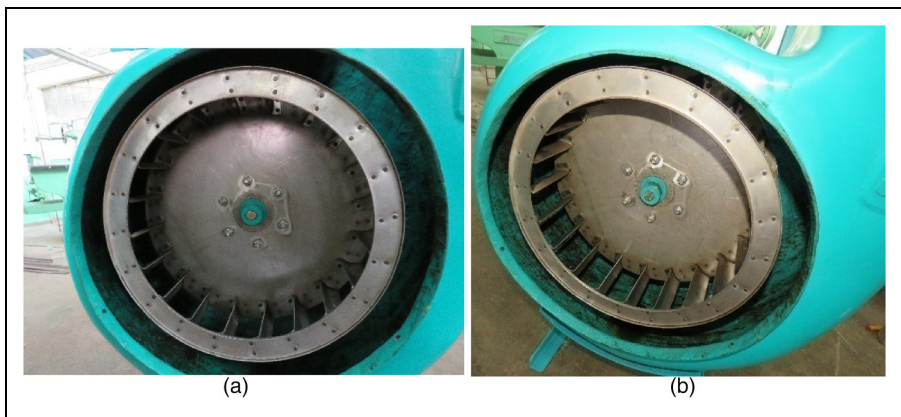

Figure 4. Impeller of blower.

Technical specifications of tractor mounted air blast sprayer

Technical Specifications of the prototype of tractor operated air blast sprayer developed for coconut tree is given in Table 1.



Figure 5. Inlet cover.

Technical performance of air blast sprayer

The height of the spray of the chemical injection pump was measured at the overhead tank of 30 m height. The chemical injection pump (diaphragm pump) is adjusted to deliver a constant discharge of $1 \text{ L}\cdot\text{min}^{-1}$ at an operating pressure of $27.5 \text{ kg}\cdot\text{cm}^{-2}$ at a speed of 540 rpm.

The sprayer was mounted on the prime mover of a small tractor with the help of the three-point linkage of the tractor. Power was taken from the PTO of the small tractor and was transmitted to the blower and the chemical injection pump through the power transmission unit. The chemical injection pump was directly connected to the blower through speed enhancing gear system with two gear ratios of 1:4.18 and 1:5.5. The topmost sample point was placed at a height of 30 m above ground. Photo sheets made from Kromekote® were fixed on square pipes to collect the spray material and kept horizontally at constant height intervals of 3 m up to 30 m. The spray material consists of water and water-soluble methylene blue at 0.75 percent concentration. After spraying, the photo sheets (Kromekote® paper) were collected and analysed for the spray characteristics viz., like volume mean diameter (VMD), droplet density and spray deposition at different vertical heights using Deposit scan software.¹⁰⁻¹² The sprayer mounted on the tractor was operated at selected tractor speeds of 1.5 (S1) and 2.5 (S2) $\text{km}\cdot\text{h}^{-1}$ and blower speeds of 2250 (B1) and 3000 (B2). The spray characteristics were calculated for all selected



Figure 6. Blower assembly.

combinations of tractor speed (S) and blower speed (B). Three replications were carried out for each experiment and were recorded. Spraying was done in the early morning to avoid the drift of spray due to wind. Air velocity was observed as 65 m.s^{-1} and 82 m.s^{-1} at a blower speed of 2250 (B1) and 3000 rpm (B2) above the height of 3 m from the sprayer outlet. Before the commencement of the experiment, it was assured that the tractor was set at the selected gear and throttle position to get specified tractor speed and blower speed.

Test location and crop characterization

Field tests were performed in areca nut plantations (Cultivar: Sreemangala; Area: 0.55 ha) at ICAR-CPCRI Regional Station, Vittal, Karnataka, India experimental farm where areca nut is cultivated as mono-crop. Eighteen years old areca nut

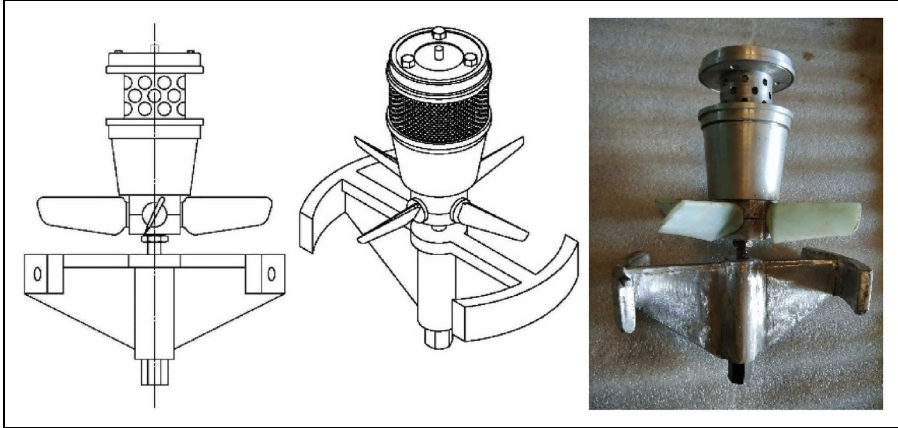

Figure 7. Atomizer.

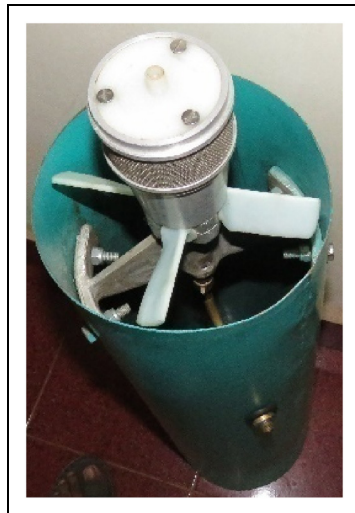

Figure 8. Atomizer inside lance.

palms were planted at 2.7×2.7 m spacing and average palm height was about 21 m. Two prophylactic sprays (first spray just before the onset of monsoon and second spray 45 days after the first spray) of four different fungicides namely Bordeaux mixture (1% and 2%), copper oxychloride (COC) (0.3%), Mandipropamid 23.3SC (0.5%) and Fenamidone 10% + Mancozeb 50% w/w WG (0.5%) was undertaken and the fruit rot disease incidence and severity were regularly monitored during the monsoon season from June to September 2019 and calculated using the following

Table 1. Technical specifications of the prototype of tractor driven air blast sprayer.

Prime Mover	Small Tractor \geq 14.7 kW/PTO – 540 rpm
Type of Nozzle	Rotary Nozzle
Type of chemical injection Pump	Diaphragm Pump
Blower	No. of fins-20 Blower speed - 2250 / 3000 rpm Blower casing: Roto-mould plastic
Power Transmission Unit	Universal Coupling with a three-point linkage of the tractor Gear ratio-1:4.18 and 1:6
Specifications of Chemical Injection Pump	Diaphragm pump Discharge rate: Variable discharge Pressure-27.5 bar at 540 rpm
Atomization Unit	Centrifugal atomization
Spray Targeting Mechanism	Motorized Universal Coupling (Long Lance adjustable in two dimensions)
Capacity of chemical Tank	200 L
Size	1270 mm \times 1219 mm \times 1981 mm
Weight	290 kg

equation (1).

$$\text{Disease severity} = \frac{\text{Total number of nuts infected}}{\text{Total number of nuts harvested} * 100} \quad (1)$$

Result and discussion

The spray characteristics viz., VMD (μm), droplet density (no. cm^{-2}) and spray deposition ($\mu\text{l cm}^{-2}$) were measured for two selected blower speeds of 2250 (S1) and 3000 rpm (S2) and tractor speeds of 1.5 (B1) and 2.5 (B2) km h^{-1} at different levels of height (3–30 m).

Effect of blower speed and operating speed on VMD (μm)

The droplet size (VMD) moderately decreased with an increase in blower speed for all selected heights (Fig. 9), this might be due to the increase in blower speed increasing the air velocity and hence, air discharge breaks the larger droplets into smaller droplets. However, the droplet size (VMD) was not much affected up to 9 m height for the selected blower speed. The reason might be spray spectrum emitted from the atomizer remain at the primary atomization stage for bigger size droplets. Therefore, the effect of blower speed on droplet size was not pronounced up to 9 m in height. At a height of 12 m, the droplet size showed smaller in droplet size compared to 9 m height which could be due to secondary atomization. From 12 m to 30 m height, the droplet size had shown decreased trend with the increase in height at all conditions. The smaller droplets produced are transported easily by air current produced by the powerful blower to greater heights, up to 30 m,

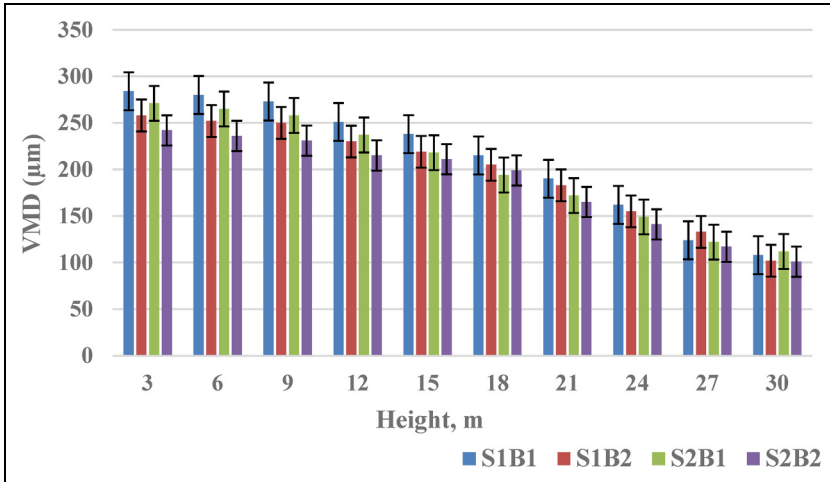

Figure 9. Effect of the combined effect of tractor speed (S1 and S2) and blower speed (B1 and B2) on droplet size (μm).

from the sprayer outlet. It also shows that the maximum mean value of droplet size was found at a blower speed of 3000 rpm with an operating speed of 1.5 kmh^{-1} whereas, the minimum mean value of droplet size was found at a blower speed of 2250 rpm with tractor speed of 2.5 kmh^{-1} . According to the American Society of Agricultural and Biological Engineers (ASABE) S572.1 standard, the fine ($106\text{--}235 \mu\text{m}$) and medium size ($236\text{--}340 \mu\text{m}$) spray class is the most commonly used spray type and used for insecticides, herbicides, and systematic-acting fungicides. The droplet size of 155, 133 and $109 \mu\text{m}$ was measured at the height of 24 m, 27 m and 30 m for the tractor speed of 1.5 km h^{-1} with a blower speed of 3000 rpm. The droplet size at a tractor speed of 1.5 kmh^{-1} with a blower speed of 3000 rpm was found within the recommended range. Hence, this parameter was selected to evaluate the developed prototype at field conditions. This confirms the recommendation for effective droplets of 100 to $200 \mu\text{m}$ reduced drift losses and pest control.^{13–15} It was also observed that increased tractor speed decreased the droplet size.

Effect of blower speed and tractor speed on droplet density (no. cm^{-2})

The droplet density increased with an increase in blower speed (Fig. 10). The reason might be due to the increase in blower speed increased the air velocity and simultaneously, the droplet density also increases by breaking the larger droplets into smaller sizes. The gradual increase in droplet density was observed at different heights above the sprayer and reached a peak at 12 m vertical height and dropped gradually and further increased at heights up to 30 m height. The highest droplet density was observed at 12 m, was due to a greater number of smaller size droplets generated during secondary atomization. After 12 m, the droplet density gradually decreased, this may be due to the completion of secondary atomization of droplets and further, the droplets are only carried

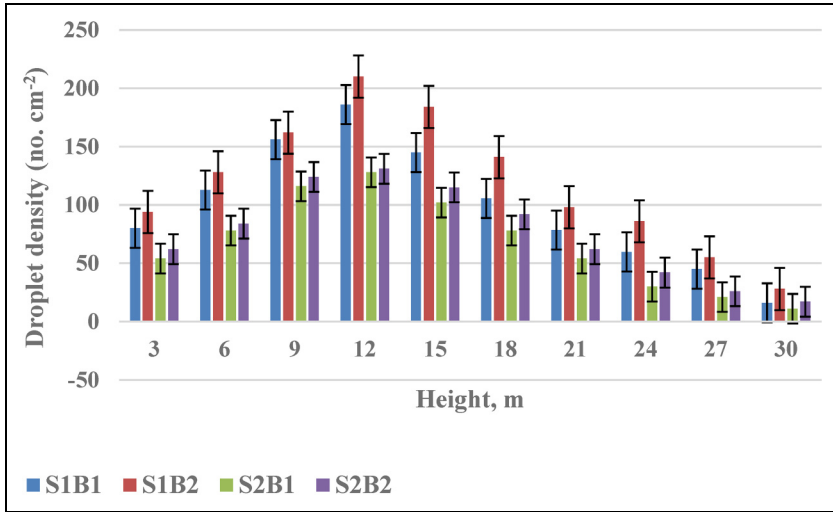

Figure 10. Combined effect of blower speed (B1 and B2) and tractor speed (S1 and S2) on droplet density (no. cm⁻²).

out to the target with the help of an air jet produced by the blower. The average spray droplet density (no.cm⁻²) for the selected combination of S1B1, S1B2, S2B1 and S2B2 at different heights were 98.46 (SD=50.2), 121.81 (SD=54.71), 67.2 (SD=38.14) and 75.5 (SD=38.3), respectively. The maximum and minimum value of droplet density was observed at 210 and 11 no.cm⁻² for the tractor speed of 1.5 kmh⁻¹ with a blower speed of 3000 rpm at height of 21 m and tractor speed of 2.5 kmh⁻¹ with a blower speed of 2250 rpm at a height of 30 m. The droplet density of 86, 55 and 31 no cm⁻² was observed for the height of 24 m, 27 m and 30 m at a tractor speed of 1.5 kmh⁻¹ with a blower speed of 3000 rpm. Syngenta Crop Protection AG, recommends that satisfactory results can be obtained by a number of spray droplets of at least 20–30 no cm⁻² for insecticide, 30–40 no cm⁻² for contact post-emergence herbicide applications and 50–70 no cm⁻² for fungicide applications. Hence, the droplet density at maximum height was found within recommended range at a tractor speed of 1.5 kmh⁻¹ with a blower speed of 3000 rpm for control of insecticide.

It was also observed that the droplet density was decreased with an increase in the operating speed of the sprayer for all the selected heights. The reason might be due to the increase in operating speed of the sprayer and reduced time of exposure of spray material to the target. A similar result was reported by.¹⁴

Effect of blower speed and tractor speed on spray deposition ($\mu\text{L cm}^{-2}$)

Spray deposition was highest near the sprayer for all blower speeds and it decreased with an increase in height (Fig. 11). This was because the energy of the air jet decreased with an increase in the target distance. This confirms that the rate of change of air-assist

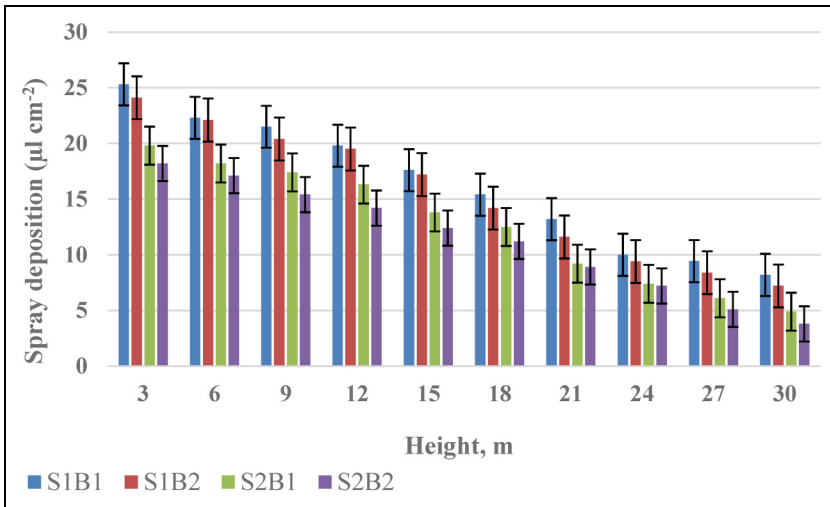

Figure 11. Combined effect of blower speed (B1 and B2) and tractor speed (S1 and S2) on spray deposition ($\mu\text{l cm}^{-2}$).

velocity was reported to decrease with increasing distances from the sprayer outlet.^{9,16} The average spray deposition ($\mu\text{l cm}^{-2}$) for the selected combination of S1B1, S1B2, S2B1 and S2B2 on height was 16.27 (SD=5.66), 15.41 (SD=5.77), 12.56 (SD=5.11) and 11.35 (SD=4.74), respectively. The maximum value of spray deposition was observed $25.3 \mu\text{l cm}^{-2}$ for the tractor speed of 1.5 kmph with a blower speed of 3000 rpm at a height of 3 m and a minimum value of $3.8 \mu\text{l cm}^{-2}$ was observed at a tractor speed of 2.5 kmph with blower speed of 2250 rpm at a height of 30 m. The spray deposition at heights above 21 m shows in the range of $13.2\text{--}3.8 \mu\text{l cm}^{-2}$. The spray deposition of 9.4, 8.4 and $7.2 \mu\text{l cm}^{-2}$ was observed for the height of 24 m, 27 m and 30 m at tractor speed of 1.5 kmh^{-1} with a blower speed of 3000 rpm. This range was an acceptable limit for the best control of pesticide application.¹⁷

The spray deposition on the target decreased by increased tractor speed. The maximum spray deposit was obtained $25.3 \mu\text{l cm}^{-2}$ at a tractor speed of 1.5 km h^{-1} and blower speed of 2250 rpm and the minimum value of the deposit was obtained $3.8 \mu\text{l cm}^{-2}$ at a tractor speed of 2.5 km h^{-1} and blower speed of 3000 rpm. The average spray deposition ($\mu\text{l cm}^{-2}$) for the selected combination of S1B1, S1B2, S2B1 and S2B2 on height were 16.27 (SD=5.66), 15.41 (SD=5.77), 12.56 (SD=5.11) and 11.35 (SD=4.74), respectively.

Field evaluation of the developed system

In evaluation, the combination of tractor speed of 1.5 km h^{-1} (S1) and blower speed of 3000 rpm (B1) was optimized and selected for field evaluation at ICAR-CPCRI, Kasaragod (Fig. 12) and ICAR-CPCRI, Vittal (Fig. 13). The mean height of the coconut crop was observed as 26 m. The mean droplet size, droplet density and

deposition were observed $124 \mu\text{m}$, 32 no cm^{-2} and $7.2 \mu\text{l cm}^{-2}$ respectively. The effective field capacity, field efficiency and fuel consumption were 0.524 ha.h^{-1} , 73.72% and 4.67 l h^{-1} .

The lowest percentage of disease severity (20.55%) was recorded in the palms sprayed manually with 1% Bordeaux mixture, followed by 36.287% in 2% Bordeaux mixture, and 47.285% in 0.5% Mandipropamid 23.3SC . Disease severity in all the treatments applied with tractor mounted air-blast sprayer was comparatively higher than with manual spray (Fig. 14). This could be due to the quantity of chemical sprayers on the target point. Manual spraying required $\sim 1.0\text{--}1.5$ liters of spray solutions per areca nut palm for a single spray. Whereas, in the case of tractor mounted air-blast sprayer the spray solution used was 300 ml . During July-August, the pathogen population could be built up due to climatic conditions and the second spray should effectively cover the entire bunch. Since the quantity of the spray solution used in manual spray is on the higher side, it could have covered evenly on the fruits. But the spray solutions from tractor-mounted air-blast sprayers might not have evenly covered the fruits, which could be the main reason for the less effectiveness under field conditions. Two to three passes in the same field may enhance the efficiency of the developed air blast sprayer or static spraying under the tree also enhances the efficiency.

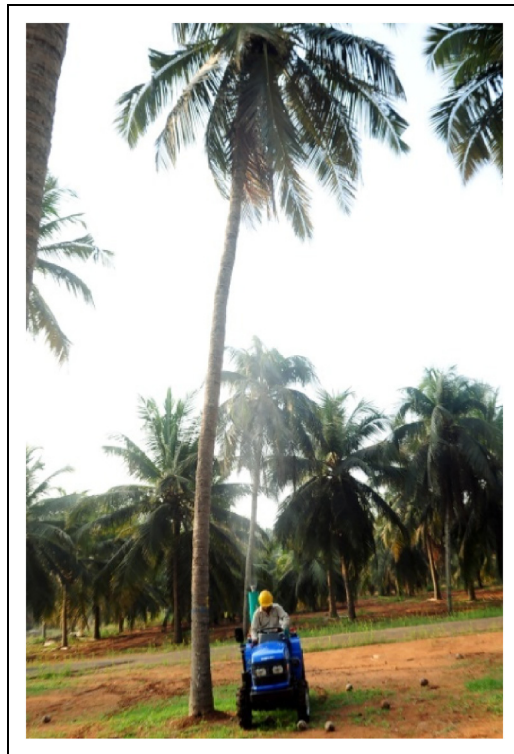

Figure 12. Air blast sprayers evaluated for coconut gardens.



Figure 13. Air blast sprayers evaluated for areca nut gardens.

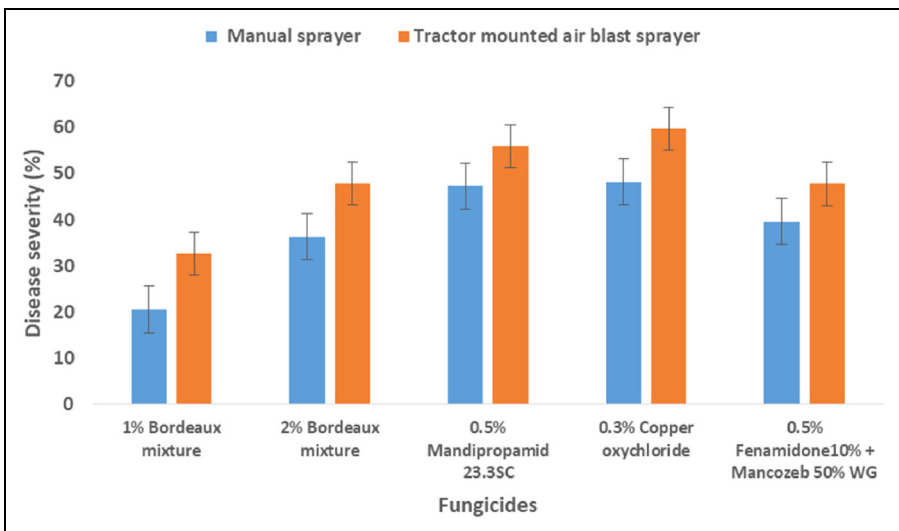

Figure 14. Comparison of performance of manual spray and air blast sprayer.

Conclusion

A small tractor-mounted air blast sprayer, operated by the PTO, was developed to spray the pesticide in coconut trees. With this machine, spraying could be done from the ground and the spray could reach up to a height of 30 m. The effective field capacity, field efficiency and fuel consumption were $0.524 \text{ ha}\cdot\text{h}^{-1}$, 73.72% and 4.67 l h^{-1} . The spray characteristics such as mean droplet size, droplet density and deposition were observed $124 \mu\text{m}$, $32 \text{ no}\cdot\text{cm}^{-2}$ and $7.2 \mu\text{l cm}^{-1}$, respectively, which are in acceptable limits. Considering the prevailing high labor charges, the air blast sprayer developed would be economically viable and much faster than any other spraying method currently available. The developed technology reduced the drudgery involved in spraying coconut trees and increased work efficiency and safety. In the future, the developed sprayer may be tested and adopted for other tall trees such as palmyrah.

Declaration of conflicting interests

The authors declared no potential conflicts of interest with respect to the research, authorship, and/or publication of this article.

Funding

The authors disclosed receipt of the following financial support for the research, authorship, and/or publication of this article: This work was supported by the Coconut Development Board, India.

ORCID iD

R. Pandiselvam  <https://orcid.org/0000-0003-0996-8328>

References

1. Abidin CMRZ, Ahmad AH, Salim H, et al. Population dynamics of *Oryctes rhinoceros* in decomposing oil palm trunks in areas practicing zero burning and partial burning. *J Oil Palm Res* 2014; 26: 140–145.
2. Manian R, Senthilkumar T and Kathirvel K. Development and evaluation of tractor operated coconut tree sprayer. *Agric Mech Asia, Africa Latin Am* 2002; 33: 23–26.
3. Cooke BK, Hislop EC, Herrington PJ, et al. Air-assisted spraying of arable crops, in relation to deposition, drift and pesticide performance. *Crop Prot* 1990; 9: 303–311.
4. Raetano CG. Air assistance in sleeve boom sprayers, http://www.jacto.com/PDF/white_papers/Airassist_sleeve_boom_sprayers.pdf (2005, accessed 20 May 2022).
5. Bock C and Hotchkiss MW. A comparison of ground-based air-blast sprayer and aircraft application of fungicides to manage scab in tall pecan trees. *Plant Dis* 2020; 104: 1675–1684. doi:10.1094/pdis-11-19-2345-re
6. Brenneman TB, Bertrand PF and Mullinix B. Spray advisories for pecan scab: recent 583 developments in Georgia. In: McCraw BE, Dean EH and Wood BW (eds) *The pecan 584 industry: current situation and future challenges, third national pecan workshop 585 proceedings, USDA agricultural research service*. 4. Washington, DC, USA: USDA Agricultural Research Service, 1998, pp.7–14.
7. Dekeyser D, Foqué D, Duga AT, et al. Spray deposition assessment using different application techniques in artificial orchard trees. *Crop Prot* 2014; 64: 187–197.

8. Dhande KG, Mathur R and Sharma A. Performance evaluation of a centrifugal blower of air assisted sprayer for orchard pesticide application. *Int J Agric Sci Res* 2016; 6: 119–130.
9. Hu Y, Yang H, Hou B, et al. Influence of spray control parameters on the performance of an air-blast sprayer. *Agriculture* 2022; 12: 1260.
10. Ferguson JC, Hewitt AJ and O'Donnell CC. Pressure, droplet size classification, and nozzle arrangement effects on coverage and droplet number density using air-inclusion dual fan nozzles for pesticide applications. *Crop Prot* 2016; 89: 231–238.
11. Qiu W, Guo H, Cao Y, et al. An electrical vortex air-assisted spraying system for improving droplet deposition on rice. *Pest Manag Sci* 2022; 78: 4037–4047.
12. Xiao Q, Du R, Yang L, et al. Comparison of droplet deposition control efficacy on phytophthora capsica and aphids in the processing pepper field of the unmanned aerial vehicle and knapsack sprayer. *Agronomy* 2020; 10: 15.
13. Bahlol HY, Chandel AK, Hoheisel G-A, et al. The smart spray analytical system: developing understanding of output air-assist and spray patterns from orchard sprayers. *Crop Prot* 2020; 127: 104977. <https://doi.org/10.1016/j.cropro.2019.104977>
14. Imran SS and Surendrakumar A. Evaluation of hydraulic energy nozzle suitable for low velocity air-assisted sprayer. *Int J Curr Microbiol App Sci* 2018; 7: 1398–1405.
15. Standard 572.1; Spray Nozzle Classification by Droplet Spectra. ASABE American Society of Agricultural and Biological Engineers: St. Joseph, MI, USA, 2009.
16. Fox RD, Derksen RC, Zhu H, et al. A history of air-blast sprayer 356 development and future prospects. *Trans ASABE* 2008; 51: 405–410.
17. Water-Sensitive Paper Check Your Spray Coverage, <https://www.syngenta.com.au/awri> (accessed 20 April 2023).

Author biographies

R Pandiselvam is actively engaged in food engineering research. After completion of doctorate studies from Tamil Nadu Agricultural University (2015), he has joined ICAR as a scientist (Agricultural Process Engineering) at Central Plantation Crops Research Institute (CPCRI), Kasaragod, India in 2016. He has contributed in design and development of minimal processing machine for tender coconut, continuous type coconut testa removing machine, tender coconut cutting machine and preservation protocol for trimmed tender coconut and also developer/co-developer many value-added food products (viz., Kalpa Krunch, Coconut Flakes, Foam-mat Dried Coconut Milk Powder, Frozen Coconut Delicacy and Matured Coconut Water based Beverages), which are commercialized to many entrepreneurs.

A C Mathew is a principal scientist working in the area of water conservation, farm mechanization, development of coconut processing equipment and dryers.

Syed Imran is a scientist in ICAR– Central Institute of Agricultural Engineering. He has completed his PhD in Agricultural Engineering in Farm Machinery and Power (FMP). His area of research is precision agriculture (PA) and automation in farm machinery and equipment.

R Thava Prakasa Pandian is scientist at ICAR-Central Plantation Crops Research Institute Regional Station, Vittal, Karnataka, India.

M R Manikantan is a principal scientist has lead role in the novel food products development from coconut, arecanut and cocoa.